



incomparably

RELATIVE CAROLINA ESPINO



The XC21 delivers the ultimate in comfort.

When summer days get long and hot, a basic air conditioner can keep you cool and relaxed in your home. The XC21 from the Dave Lennox *Signature*® Collection keeps you completely exhilarated. But as good as the XC21 makes you feel, what's even cooler is the innovation behind it. Precision-engineered with two-stage technology, it **automatically provides more or less cooling as necessary to maintain a consistent temperature throughout your home.** All the while, it's working to keep energy costs and sound levels at an absolute minimum.

Quite simply, it's the quietest and most efficient two-stage central air conditioner you can buy.* So it's not only beyond cool—it's also beyond compare.

*A combination of sound ratings established per AHRI's test standard: 270-2008; and efficiency ratings established per AHRI's test standard: ANSI/ARI 210/240-2008 of two-stage central AC/HP equipment.



innovation that's incomparably cool

Virtually silent

Exclusive SilentComfort™ technology makes the XC21 **up to 20% quieter than a standard air conditioner.**** An industry-exclusive composite fan design, two-stage operation and an insulated compressor compartment also help reduce sound levels.

SEERiously efficient

With industry-leading efficiencies of up to 21.20 SEER, **the XC21 can save you hundreds of dollars each year** on your utility bills.

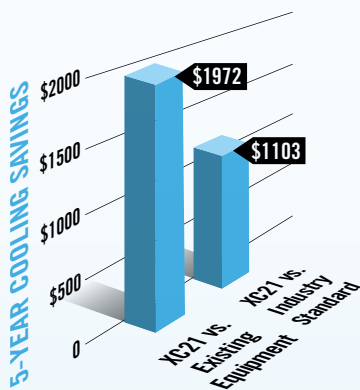

SEER stands for "Seasonal Energy Efficiency Ratio" and is a measure of a central air conditioner's efficiency and performance. The higher the SEER, the greater your energy savings. Typical SEER ratings range from 13 to 18, but the XC21 carries ratings as high as 21.20.

This chart compares the 5-year savings you can expect from a 21.00 SEER air conditioner vs. existing equipment with a 10.00 SEER rating and industry-standard equipment with a 13.00 SEER rating. The regions used to calculate household fuel and utility costs reflect a cross-section of cities in the U.S. In addition to geography, cooling costs are based on 3-ton capacity specifications, with 1,800 cooling hours per year and 11.62 cents per kWh (Source: EIA National average electric rate—Rolling 12 months ending in July 2009). Your actual costs will vary depending on the weather, local fuel rates, systems settings and your personal lifestyle.



XC21

The quietest and most efficient two-stage central air conditioner you can buy*

**Sound Rating Number according to ANSI/AHRI Standard 270-2008. "SRN" is the overall A-weighted Sound Power Level, (LWA), dB (100 Hz to 10,000 Hz). Sound information based on 3 ton models. Standard system is a 13ACX with a 76dB sound rating.



One-of-a-kind cooling that's kinder to the environment.

Two levels of operation for a higher level of comfort and efficiency

The XC21's scroll compressor has two stages of operation: high for hot summer days and low for milder days. Since the low setting is adequate to meet household cooling demands 80% of the time, **the XC21 runs more efficiently and produces more even temperatures**, compared to conventional single-stage systems. Two-stage cooling cycles also translate to quieter, more efficient operation and enhanced humidity control.

Exclusive motor and fan design for an added performance edge



The SilentComfort™ outdoor fan motor with composite fan blades uses **the latest in electronic sensor technology** to optimize overall system performance.

Intelligent motor design detects a blocked fan and will automatically compensate in an effort to protect the motor or clear the obstruction. The fan then resumes normal operation, keeping the air conditioner running at peak efficiency.

Customized comfort meets your needs inside and out



The XC21 is also compatible with the Humiditrol® whole-home dehumidification system for improved air quality inside your home. By reducing humid conditions in your home, the Humiditrol system minimizes mold and mildew problems as well as airborne pollutants.



The simplest way to bring money-saving **SOLAR POWER** into your home

The SunSource® Home Energy System reduces the amount of electricity needed from your utility provider to put you in control of your utility bills. This energy-saving system harnesses solar energy and uses it first—before using electricity from the utility company—to power your air conditioner. The solar power that's collected can also operate other appliances and electronics when the heating and cooling system is not in use. What's more, if the SunSource system generates more solar power than is needed, that power will be sent back to the utility company, possibly entitling homeowners like you to a credit. Ask your Lennox Dealer for more information.



The XC21 has earned the ENERGY STAR® Most Efficient 2013 label, which means it is recognized as one of the most efficient products that qualify for ENERGY STAR.

We're obsessed with the pursuit of creating perfect air, and doing so with absolute efficiency.



Since 1895, Lennox has been on a continuous quest to reinvent home comfort. Perfect air is our purpose and our obsession. Today, that pursuit takes shape in many innovative ways: the most precise and energy-efficient air conditioners, the quietest high-efficiency furnaces, heat pumps, Wi-Fi-enabled thermostats, air handlers, air cleaners, small-space comfort systems, boilers and more.



Peace-of-mind protection

The XC21 comes with a 10-year limited warranty on the compressor and all remaining covered components.*



Dealers you can count on

You can trust Lennox Dealers to design the right system for your home, install it properly and keep it running perfectly for many years to come. Because Lennox has more than 6,000 dealers throughout North America, you can rest assured there's a dealer near you.



Industry-leading energy innovation

The XC21 is Lennox' first residential air conditioner rated up to 21.20 SEER. Compared to conventional cooling systems, it can save you hundreds of dollars on your utility bills each year (see chart on page 3). As one of Lennox' most efficient and advanced energy innovations, it carries a green *Signature* badge and has earned the ENERGY STAR® label. Beyond cost savings, this badge gives you peace of mind in knowing the XC21 is a better choice for the environment.

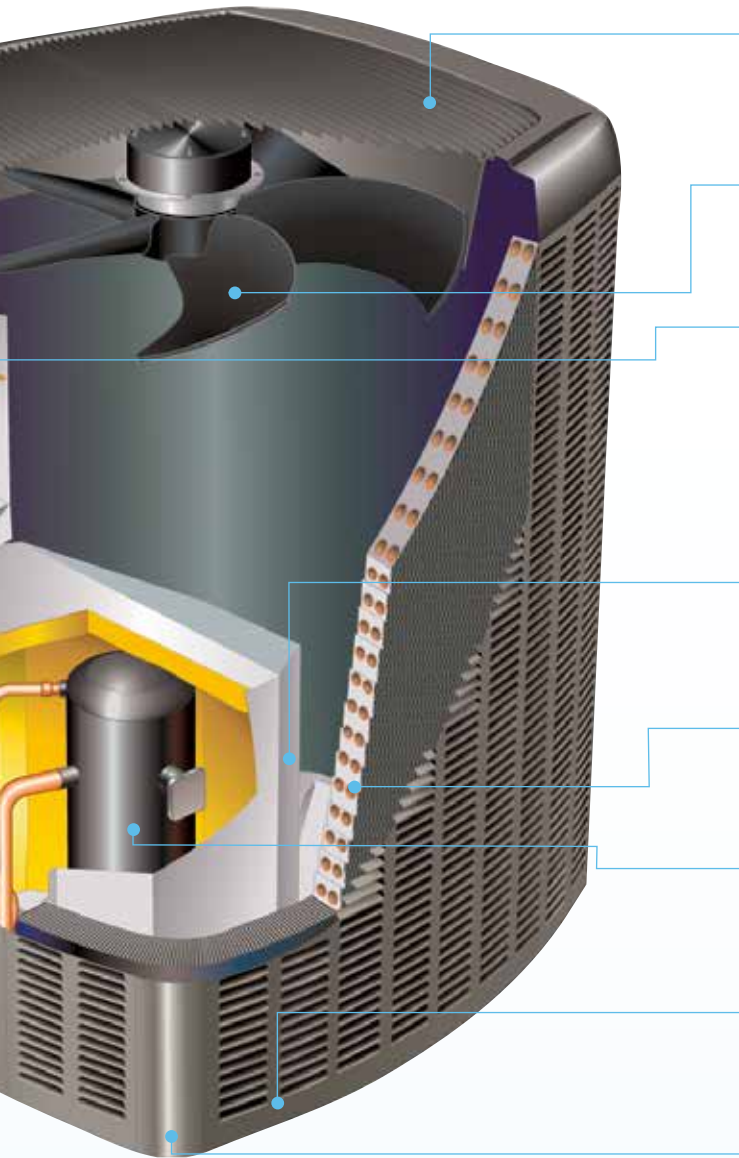

SilentComfort™ Fan Grille – Uses patent-pending, vortex-suppression technology to reduce sound of airflow exiting unit, providing a quieter environment outside your home.

SilentComfort Outdoor Fan Motor with Composite Fan Blades – Provides extremely reliable starting and running performance, even under the harshest outdoor conditions.

iComfort™-Enabled Technology – Allows the XC21 to exchange information with other home comfort system components and make adjustments as needed to optimize performance and efficiency.

Humiditrol® Compatible – Manages the moisture in your home's air for greater comfort and improved indoor air quality.

Insulated Compressor Compartment – Uses industry-leading, vibration-isolating mounts and other innovative materials to minimize operating sounds.

High-Efficiency Outdoor Coil – Provides exceptional heat transfer and low air resistance for high-efficiency operation that can lower your cooling bills.

Two-Stage Scroll Compressor – Operates at low stage most of the time for quieter, more energy-efficient performance. Plus, it uses the U.S. EPA–approved R-410A refrigerant.

PermaGuard™ Cabinet – Heavy-gauge, galvanized steel construction, louver coil guard, baked-on powder finish and durable zinc-coated steel base provide long-lasting protection against rust and corrosion.

SmartHinge™ Louver Design – Allows quick, easy access to interior components from all sides, so the unit can be serviced in minimal time.



Dave Lennox Signature® Collection XC21 Specifications

Model	024	036	048	060
SEER	Up to 21.20	Up to 19.70	Up to 18.50	Up to 16.50
Sound Rating – dB	69	71	73	73
Dimensions H x W x D (in)	47x35-1/2x39-1/2	47x35-1/2x39-1/2	47x35-1/2x39-1/2	47x35-1/2x39-1/2
H x W x D (mm)	1194 x 902 x 1003	1194 x 902 x 1003	1194 x 902 x 1003	1194 x 902 x 1003

Note: Due to Lennox' ongoing commitment to quality, all specifications, ratings and dimensions are subject to change without notice. Always verify actual system efficiencies through AHRI or by visiting the AHRI ratings database at www.ahridirectory.org. *Applies to residential applications only. See actual warranty certificate for details.



Lennox is proud of the fact that these products have earned the Good Housekeeping Seal.



Proper sizing and installation of equipment is critical to achieve optimal performance. Split system air conditioners and heat pumps must be matched with appropriate coil components to meet ENERGY STAR® criteria. Ask your Lennox Dealer for details, or visit www.energystar.gov.

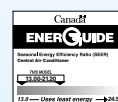

Intertek

A system of innovative products, all working perfectly together.

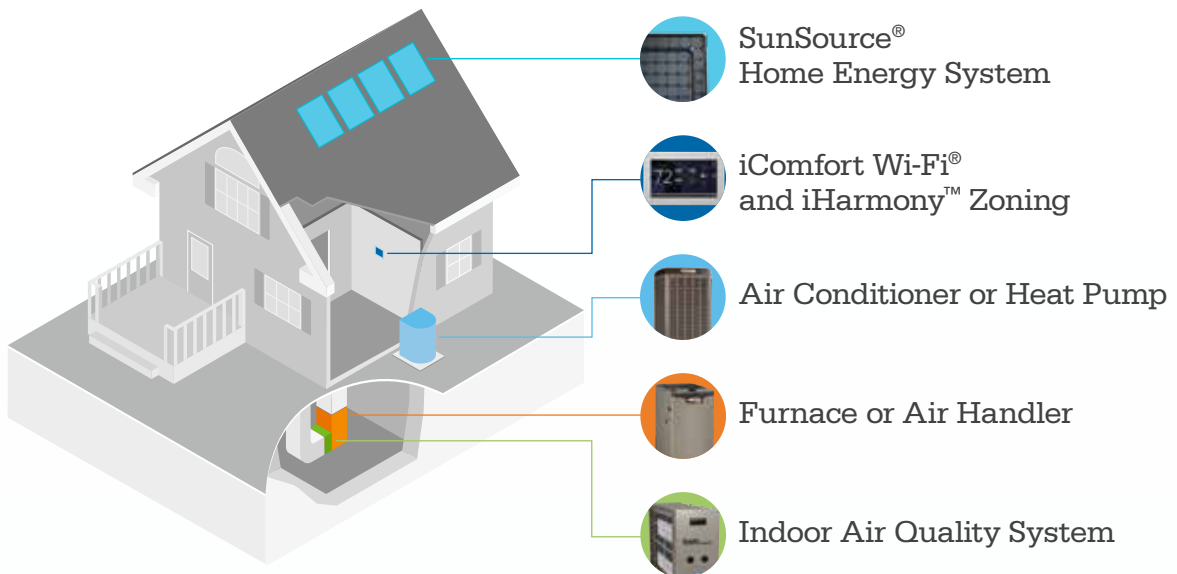

Every Lennox® product is a standout on its own. Working together in one system, Lennox products fill your home with air that's perfectly heated and cooled, and they do so with absolute efficiency.

Why choose a complete system?

Indoor and outdoor units can only operate at their peak potential when they are compatible with each other in type and size, as well as performance capabilities. By combining Lennox products that are made to work together, you can create an ideal system for your home.



Innovation never felt so good.®

For a complete list of the registered and common law trademarks owned by Lennox Industries Inc., please visit www.lennox.com.